

VIKRANT **SPECIAL MACHINES**

Vikrant special machines private limited

ISO 9001:2015

Company Profile Presentation

Company Profile

A professionally managed company, Vikrant Special Machines is engaged in the sphere of development of special purpose machines since 1969.

The company was started by a group of young, enthusiastic and dynamic Machine Tool engineers with the motto to offer innovative design input to Engineering industries across India.

Vikrant Special Machines was born in 1976 with a prototype manufacturing and production workshop in Kolkata. We manufacture and supply an extensive range of products such as Coil Winding Machines & accessories, Pipe & Bolt Threading Machines, Hydraulic Platforms, Railway workshop equipment, Welding Automation Equipment and Special Purpose Machines.

Our company follows industrially accepted standard design & manufacturing practices supervised by qualified professionals who have long experience in the field of machine building.

INFRASTRUCTURE

VIKRANT has three units - one located in Jessore Road and another two in Dankuni with basic machine tools and inspection equipments.

VIKRANT is proud of its qualified and experienced engineering staff and highly skilled ,intelligent and bold work force-second to none in the industry for the type of developmental work that VIKRANT had been doing for more than three decades now. Vikrant's moto continues to be SERVICE,QUALITY & INNOVATION.

VIKRANT engineers have developed a comprehensive range of standards and have established a work ethic tailored to achieve its above goals.

A few facts about VIKRANT SPECIAL MACHINES PVT. LTD.

(Unit I) Area-5000sq.feet

Registered Office

90,Nayapatty Road,
Kolkata-700055

Phone: 033-25513070 / 033-25501462

Fax: (91)(33)25513070

(Unit II) Area-6500sq.feet

Jagadishpur Haat,Makaltala
Howrah-71328
West Bengal

(Unit III) Area-62640sq.feet

Site under development /construction

Administration sales & marketing office

Office Area - 2000 Sq. Feet

Jeebanalay Apartment , 1st floor
Rajarhat Main Road,Jhangra
Beside Arati Cinema Hall
Kolkata-700059

Staff Strength

| Post | Number of Post |
|--------------------------------|-----------------------|
| <i>General Manager</i> | 01 |
| <i>Manager Production</i> | 02 |
| <i>Quality Control Manager</i> | 01 |
| <i>Sr. Design Engineer</i> | 01 |
| <i>Draftsman</i> | 03 |
| <i>Quality Engineer</i> | 02 |
| <i>Assembly Supervisor</i> | 02 |
| <i>Sales</i> | 03 |
| <i>Accountants</i> | 02 |
| <i>Purchase Assistant</i> | 01 |
| <i>Store in charge</i> | 01 |



Workmen Strength

| Post | Number of Post |
|---------------------|-----------------------|
| <i>Skilled</i> | 15 |
| <i>Semi Skilled</i> | 12 |
| <i>Un-Skilled</i> | 04 |



Softwares used for design & development

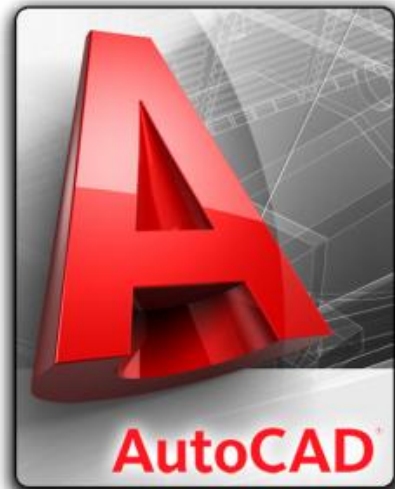

QUALITY MANAGEMENT

VIKRANT'S process for quality Management embraces control of all aspects from incoming materials upto dispatch of machines. Quality starts from design optimization, detail checking of drawings, process planning for manufacture of components, testing of input raw materials, dimensional checking of manufactured components, verification of sub assemblies & final inspection & testing of completed machine.

Accordingly the Quality Control Department is staffed with qualified and experienced men and equipped with precision measuring equipment and Tools.

Quality process is continually updated. Special care is taken to update all drawings as regard changes made during manufacture of the equipment, so that the company can provide support of spares during the entire life time of the machine.

After Sales Service' section administratively reports to Sales Department but is in close co-ordination with Quality Control & Design Department for continued improvement of design, materials, workmanship, method of manufacture , assembly and aesthetic appearance of the machine.

At VIKRANT, next only to safety.

Quality comes first and foremost.



Product Segments

Transformer Industry Products



Machines for Electrical Industry



Railway Workshop Products



Hydraulic Elevating Platforms



Welding Automation Products

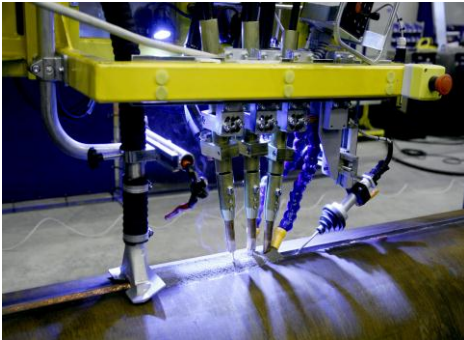

Pipe & Bolt Threading Machines



Special Purpose Machines

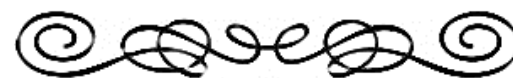

Transformer Industry Products



Coil Winding Machine



Coil Assembly Platform

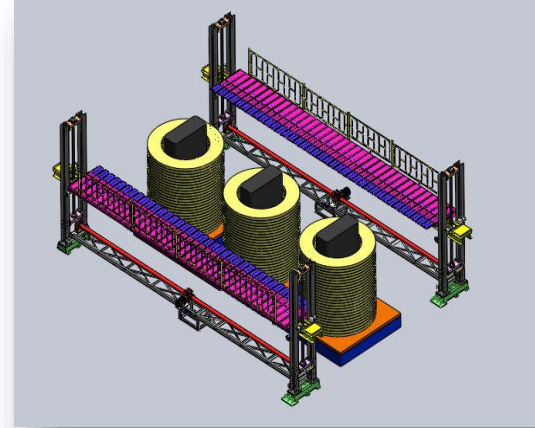

Active Part Assly. Platform

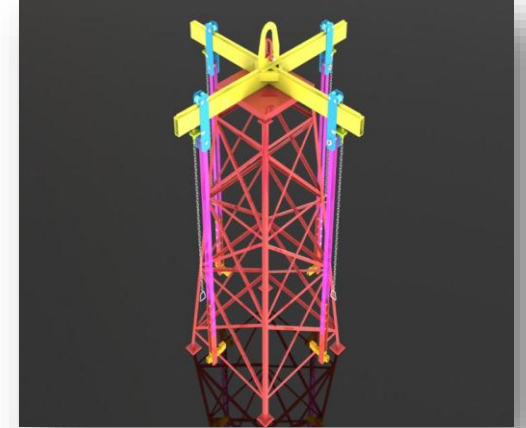

Coil Lifting Tackle

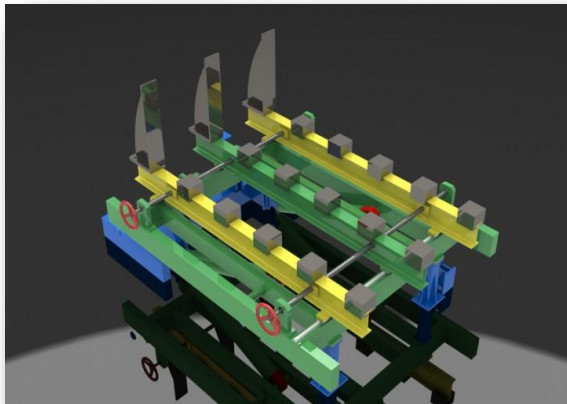

Core Tilting Table

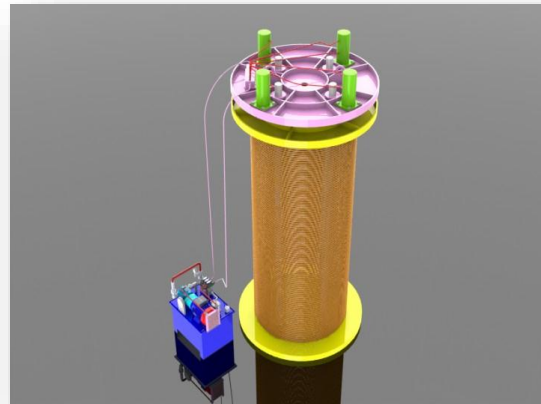

Coil Pressing Fixture



Coil Upender

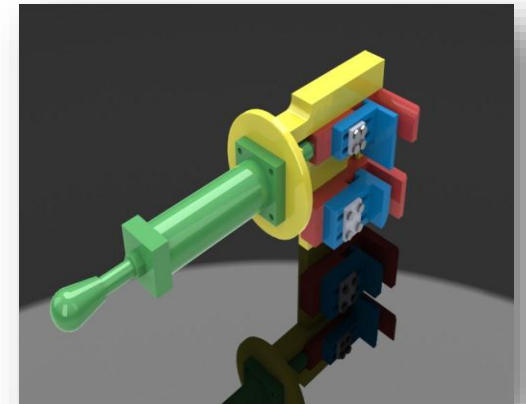

Hydraulic Transposition Tool

Transformer Industry Products

Vertical Coil Winding Machine



Vertical Coil
Winding Machine – Pit Type



Vertical Coil
Winding Machine – Floor Type



Collapsible Winding Former

Machines for Electrical Industry

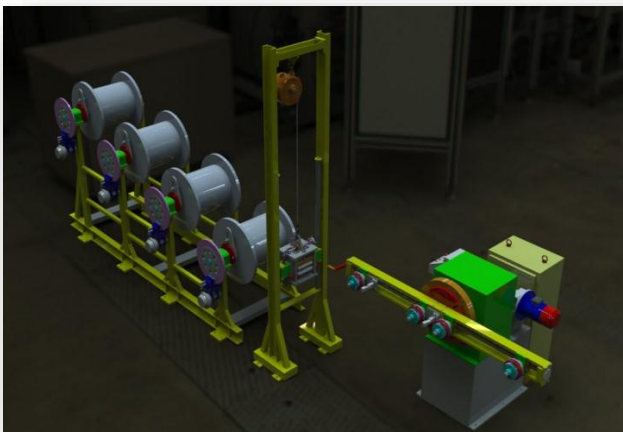

Loop Winding Machine



Armature Banding Machine

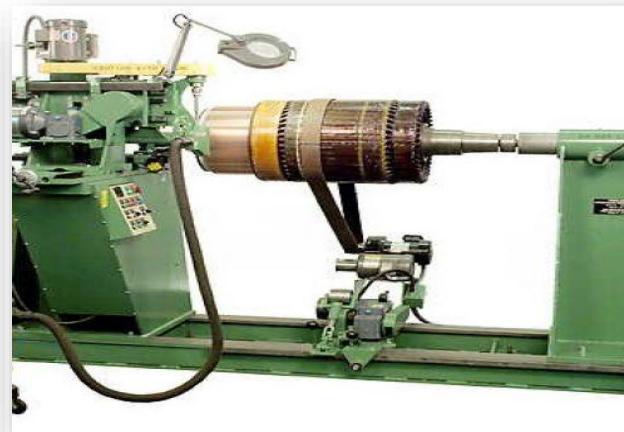

Mica Under Cutting Machine



Rotor Winding Machine

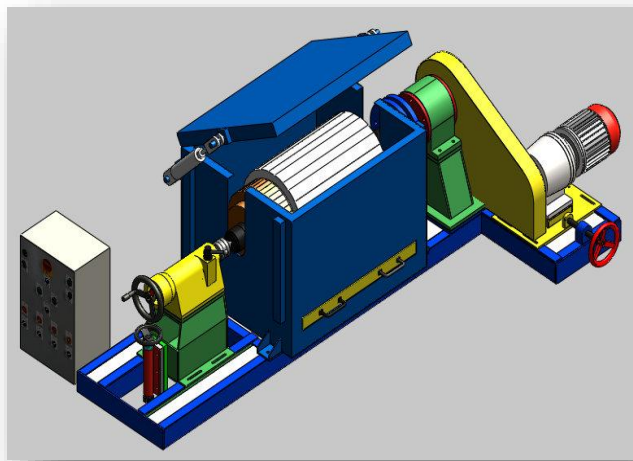

Rotary Oven/Rotary Gelation Plant



Automatic Commutator Tig Welding Machine

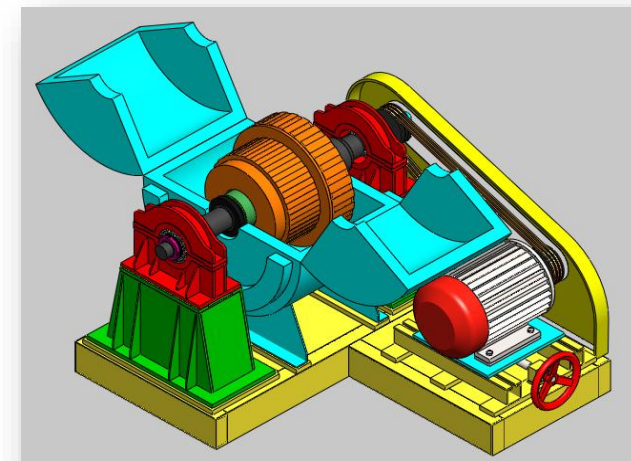

Commutator Seasoning Plant

Railway Workshop Products



Load Turning Device



Motorised Turntable For Bogie & Wheelset

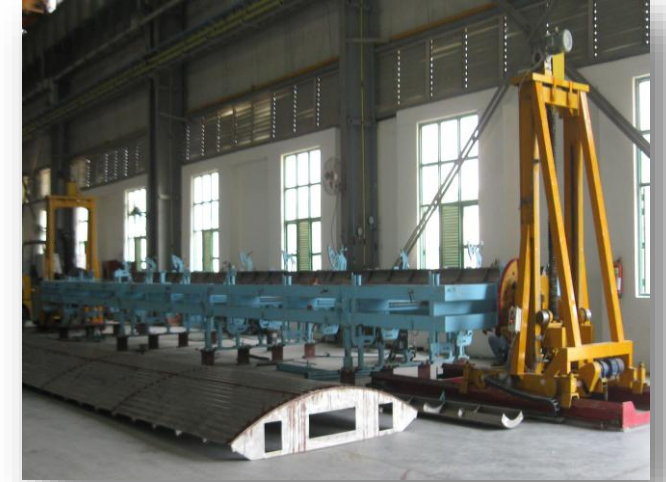

Lifting & Turning Device/Manipulator



Bogie Frame Lifting Tackle Cum Bolster Pressing Fixture

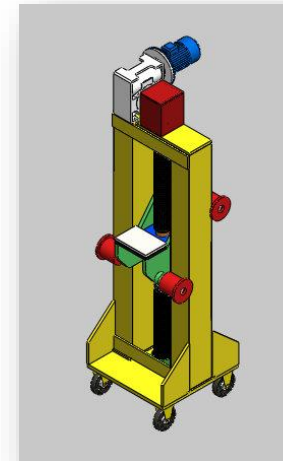

Synchronized Screw Jack

Hydraulic Elevating Platforms



Telescopic Type



Scissor Type

Welding Automation Products



CNC Profile Cutting Machine



Rotator



Column and Boom



Rotary Tilt Turn Table



Mig Welding Machine-for longitudinal welding

Pipe & Bolt Threading Machines



OPD Series



PD Series



WPD Series



WPD2E – PVC PIPE THREADING MACHINE

Special Purpose Machine



C Frame Hydraulic Press



Bar Chamfering Machine



Tool Washing Machine



3 Axis Milling Machine



Industrial Transfer Car/Motorized Trolley



Portable Flange Turning Machine

“customers”

- *A satisfied Customer is the best business strategy of all*
 - *Once a Customer always a Customer*
- *One Customer well taken care of is worth thousands of Rupees of Advertisement*
- *True test of Customer service support is not when things are going right, but rather what is done when things go wrong – Steve Ferrante*
 - *It takes months to find a Customer and only seconds to lose one*
 - *Your most Unhappy Customers are your greatest source of learning – Bill Gates*
 - *Quality is remembered long after price is forgotten*
- *It is not the Employer who pays the wages. Employer only handle the money. It is customer who pays the wages. – Henry Ford*
 - *If we don't take care of our Customers someone else will.*
 - *All your Customers are partners in your mission – Shep Hyken*
 - *Respect is earned. Honesty appreciated. Trust is gained. Loyalty is returned.*
 - *Be thankful for Customers who complain. You still have the opportunity to make them happy.*
- *The magic formula that successful businesses have discovered is to treat Customers like guests and employees like people – Tom Peters*
- *Customers don't expect you to be perfect. They do expect you to fix things when they go wrong*
Based on the above guiding principle, VIKRANT has been able to retain almost cent percent of its customer base over the last 40 years.

List of customers

Railways/Defence/Govt. Sectors



And many more...

Transformer Industries



And many more...

Transformer Industries - Export



Bangladesh



Mexico



Oman



Kuwait



And many more...

Electrical Industries

NGEF

USHA[®]

MEHER[®]
G R O U P



E/M **ELEKTROMAG**[™]

Threading Machines

Ori-Plast

PATTON

 **BMWIL**
BMW Industries Ltd

 **ऑयल इंडिया लिमिटेड**
Oil India Limited

Bansal Polymers

SHREE PLASTICS

ashirvad
PIPES

And many more...

Other Valued Customers



IFB



EPCOS



PETE - Hammond
Transformative Synergy



VESUVIUS



KEC
KEC INTERNATIONAL LIMITED



SkipperSeil Limited



Vinar
Systems Private Limited



TIL Tractors India



Kirloskar



VOLTAS
A TATA Enterprise



WPIL
WPIL Limited



KEL
KERALA ELECTRICAL & ALLIED ENGG. CO. LTD.
A Government of Kerala Undertaking



SHREE ABIRAMI ENGINEERING WORKS

And many more...



VIKRANT **SPECIAL MACHINES**

Vikrant Special Machines Private Limited

ISO 9001:2015

*Address: - 90, NAYAPATTY ROAD, KOLKATA – 700 055
WEST BENGAL, INDIA*

E-mail: info@vikrantspecial.com / sales@vikrantspecial.com

Web: www.vikrantspecial.com

Contact No: +91 9831189283 / 9831038251
+91 9748779630 / 7890005373

Thank You for Watching Our Presentation